

Solid Set Wastewater Irrigation System for Controlled Grazing

The number of concentrated livestock and poultry operations increases each year in Alabama. These farms produce large numbers of animals and, as a result, large quantities of manure and wastewater. These by-products must be disposed of in an environmentally safe way to protect water quality. Using these organic resources in land application with sprinkler irrigation can result in more effective and more economical farm production.

Most swine production facilities and many poultry layer and dairy units use lagoons for manure treatment. When these lagoons reach their holding capacity, the operator must decide how to make good use of the nutrient-filled liquid. Land application is the obvious choice with sprinkler irrigation usually being the most cost effective method. This publication describes the minimum design criteria for a solid set irrigation system for application of wastewater for controlled grazing.

Several factors to consider when planning to irrigate include land availability, target crops, and farm objectives. Also, the irrigation equipment used must match the characteristics of the specific wastewater. Wastewater storage capacity and pretreatment ability, both a function of lagoon size, affect the degree of management required for land application of wastewater. Swine, dairy, and poultry layer lagoon design and management are covered in detail in Extension Circulars ANR-973, ANR-963, and ANR-971, respectively.

Controlled Grazing

Land application with sprinkler irrigation is an innovative way to use wastewater on bermudagrass or tall fescue pastures for cattle grazing. The intensively managed pasture is divided into small paddocks sized for a group of animals to uniformly graze the grass in 1 to 3 days before being moved to another paddock.

Paddocks are irrigated on the day after the cattle are moved to encourage maximum forage regrowth. This also reduces direct consumption of the waste which sticks to the grass. Uneaten grass is harvested as hay.

Rotation of cattle to new paddocks continues until there is sufficient regrowth in the first paddock. The cycle then repeats. Pastures can be kept in good condition with livestock lagoon wastewater and without additional fertilization. Supplemental water may be needed in dry weather.

Paddocks should be large enough to provide high-quality grazing for the cattle but small enough to force uniform grazing within 3 days, before cattle are moved to the next paddock. There should be enough paddocks to allow 2 to 3 weeks between grazing events for pasture regrowth. This is dependent on the grass species. Fencing square paddocks costs less than fencing other pasture shapes. A 4:1 pasture length to width ratio should not be exceeded, especially if shade and water are not provided in the pasture. Compaction problems can be caused by too much traffic.

Applying nitrogen at optimum agronomic rates, including nitrogen from direct deposit of cattle manure, is the basis for system design. The required pasture acreage is determined by the nitrogen requirements of the pasture grass species and the total amount of nitrogen and wastewater produced during the lagoon pump-down interval (the wastewater storage period, usually from 180 to 360 days).

The amount of wastewater applied at each irrigation will depend on the nitrogen requirement of the particular grass species, available space for holding irrigation water in the soil, and nitrogen content of the wastewater. When lagoon liquid has been diluted by rainfall or freshwater flushing, the amount of wastewater applied to meet forage nutrient needs must be increased.

Solid Set Irrigation Layout

Good irrigation design is always site specific. Even though there is not a standard layout for solid set wastewater irrigation systems, there are some general guidelines that can be helpful.

- **Bury plastic pipe.**

Class 160 PVC (120 psi maximum operating pressure) plastic pipe is typically buried 18 to 36

inches belowground for mains, submains, and laterals in most permanent irrigation systems. Instead of installing permanent sprinkler risers in all sprinkler locations, 1-inch swing joints of either Schedule 40 or Schedule 80 PVC can be used to connect the laterals to quick coupling valves just below ground level. A 1-inch diameter galvanized steel or PVC riser, 12 to 18 inches tall and with a built-in key, is used to connect the sprinkler to the quick coupling valve.

Extremely rocky soil or extremely wet conditions usually require thicker walled, stronger pipe, either Class 200 or Schedule 40 PVC for mains, submains, and laterals.

• **Use desired irrigation application rate and nozzle flow rate to determine sprinkler spacing.**

An application rate no greater than 0.30 inch per hour and a minimum nozzle size of 1/4 inch are generally accepted wastewater irrigation industry guidelines. Based on this, a suggested sprinkler spacing is 80 feet by 80 feet. Normal wastewater sprinkler spacing is 60 percent of sprinkler wetted diameter, the recommendation for regular irrigation with a 0 to 3 MPH wind. For 80-foot spacing, a sprinkler wetted diameter of no less than 133 feet (80 ft. / 0.60) is required. Recommended nozzle pressure is 50 to 60 psi.

• **Install enough sprinklers to irrigate an individual paddock or at least an acre at one time.**

The total number of sprinkler locations should be an even multiple of the number of sprinklers in a single irrigation set. Sprinklers with 1/4-inch nozzles at the suggested 80-foot spacing and 55 psi will have an application rate around 0.20 inch per hour, and will take 5 hours to apply 1 inch. The same sprinkler with a 9/32-inch nozzle at 55 psi will apply about 0.26 inch per hour, which is 1 inch in 4 hours. Each paddock should be irrigated immediately after it is grazed.

Table 1 lists the manufacturer's specifications of three brands of sprinklers that meet these requirements. These and other suitable brands are available through most agricultural irrigation dealers. The plastic Senninger sprinkler, specially made for wastewater applications, has stainless steel springs and fulcrum pin. The Rain Bird and Nelson sprinklers are brass.

Although these sprinklers will operate at pressures greater than 50 to 60 psi, higher pressures increase the discharge rate and diameter of coverage and produce smaller droplet sizes that have an increased potential for drift. Lower pressures reduce the discharge rate and diameter of coverage and give larger droplet sizes.

Table 1. Irrigation Sprinkler Characteristics.

Nozzle Size, inch	Pressure (psi)					
	50		55		60	
	Flow gpm	Dia. ft.	Flow gpm	Dia. ft.	Flow gpm	Dia. ft.
Nelson F70APV						
1/4	12.8	128	13.6	131	14.0	134
9/32	16.0	134	16.8	137	17.6	140
Rain Bird 70 CWH						
1/4	12.9	124	13.6	126	14.2	128
9/32	16.3	131	17.2	133	18.0	135
Senninger 7025 RD-1-1 EFF						
1/4	13.0	127	13.6	131	14.2	135
9/32	16.3	133	17.1	137	17.8	142

Quick coupling riser valves, with covers, reduce initial cost several hundred dollars per acre by allowing the moving of sprinklers from lateral to lateral. An inexpensive way to protect the quick-coupling riser valve is by burying a cement block at field surface around each valve, then filling the core with sand or fine gravel around the riser valve (Figure 1).

• **Locate the main line by considering the field size, shape, and proximity to the lagoon.**

For simpler system operation, only full circle sprinklers are recommended. Locating the outside sprinkler about 100 feet from buildings, roads, property lines, watercourses, and drainageways reduces the risk of spraying wastewater to an area where it is not desired. Although an area around the outside edge of the pasture receives less fertilization, water quality is protected.

• **Choose lateral pipe size so that the pressure difference among sprinklers will not exceed plus or minus 10 percent of the recommended sprinkler operating pressure.**

By not exceeding plus or minus 10 percent of the recommended operating pressure, an acceptable, uniform sprinkler application is maintained along the lateral. On level ground with a 50-psi sprinkler pressure, maximum allowable pressure difference due to friction will be plus or minus 5 psi (0.10 × 50). Pressure at the first sprinkler will be 55 psi, with 45 psi on the last sprinkler. This procedure reduces discharge rate and diameter of coverage differences between the first and last sprinklers on the lateral.

Table 2 lists the maximum number of sprinklers, using two nozzle and three pressure combinations, that can be used for different sizes of Class 160 PVC based on the plus or minus 10 percent rule. This is for an 80 feet by 80 feet design sprinkler spacing, the first sprinkler being 40 feet from

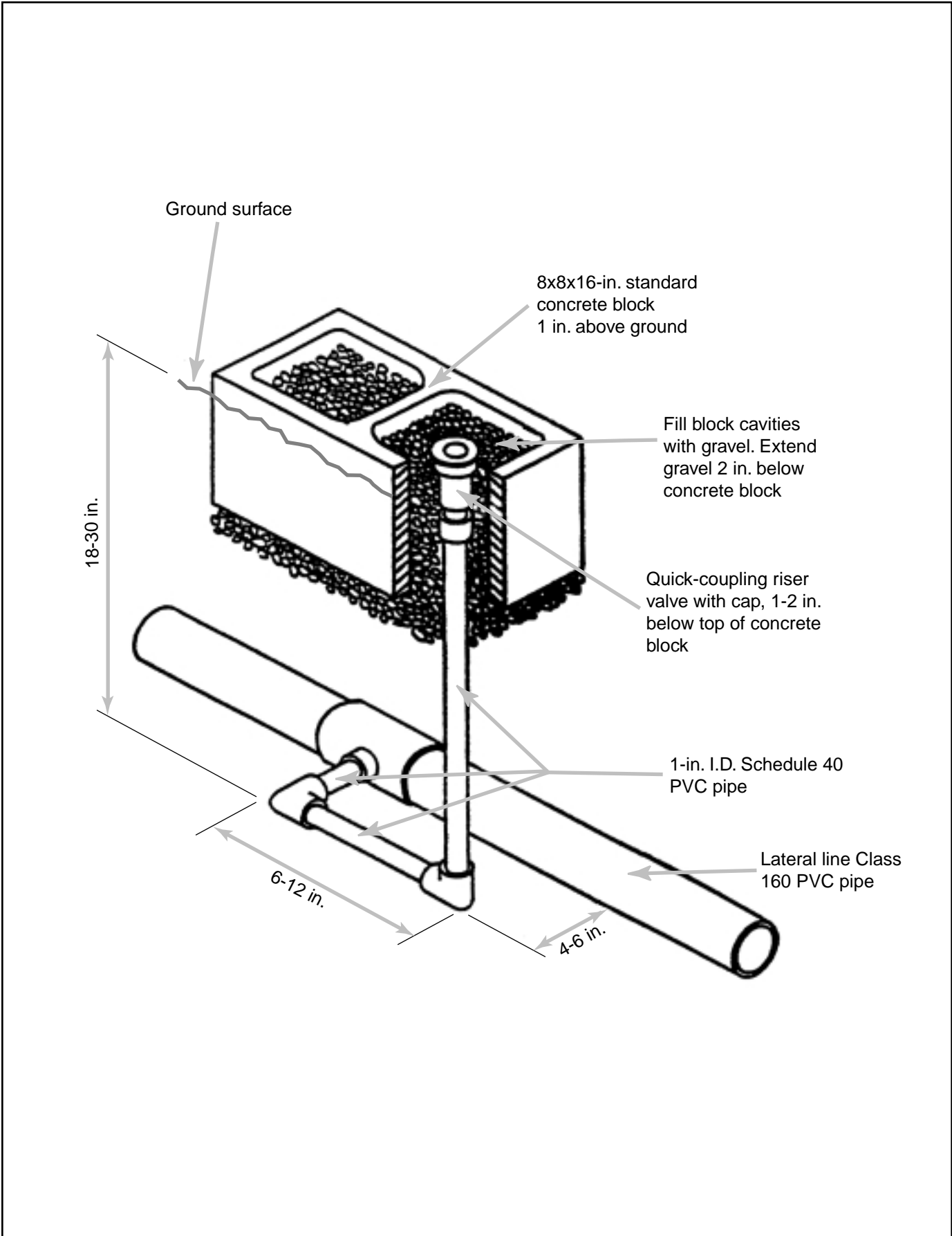

Figure 1. Swing Joint for Quick-Coupling Riser Valve.

the main line. This gives the maximum allowable number of sprinklers per lateral. Using fewer sprinklers gives more uniform distribution. The lateral should be extended 5 to 10 feet beyond the sprin-

Table 2. Maximum Allowable Number Of Sprinklers Per Lateral Line.*

Size Of Lateral PVC Pipe, inches	1/4-inch nozzle			9/32-inch nozzle		
	50 psi	55 psi	60 psi	50 psi	55 psi	60 psi
1¼	3	3	3	—	—	—
1½	4	3	3	3	3	3
2	6	6	6	5	5	5
2½	10	9	9	8	8	8
3	13	12	12	11	11	10
4	20	20	19	17	17	16

* Based on using one Class 160 lateral pipe size.

klers to collect trash that otherwise may clog the last sprinkler.

Quick-coupling riser valves are closed when a sprinkler is not installed. Using these valves in the sprinkler positions gives the option of not installing individual lateral cut-off (gate) valves. Installing gate valves on individual laterals does allow irrigation without filling the entire pipeline system with water each time the pump is started.

• **Choose PVC pipe size so that flow velocity will not exceed 5 feet per second (fps).**

A detailed, site-specific design uses several pipe sizes for the lateral line so that flow velocity will not exceed 5 fps. Most designers, however, use only one or two pipe sizes to simplify equipment purchase and installation.

The main line supplying water to the laterals is also sized to keep flow velocity from exceeding 5 fps. Table 3 gives maximum flow rate for different main line pipe sizes to do this.

Table 3. Maximum Main Line Flow Rate For Class 160 PVC Pipe.*

Pipe Size, inches	Flow Rate, gpm
2	55
2½	85
3	125
4	210
6	450

* If Class 200 or Schedule 40 PVC pipe is used, the designer should consult the proper friction loss and velocity tables. Maximum flow rate will be lower than that shown for Class 160 PVC.

Pumps

Regular centrifugal pumps used for normal irrigation are usually used for land application of wastewater and are typically powered by direct drive electric motors. This type pump is twice as efficient as a solids-handling pump and can be used to pump swine, dairy, and poultry lagoon wastewaters that are relatively free of solids. Neither this type pump nor the sprinklers discussed in this circular are recommended for lagoon slurries or wastewaters with solids contents greater than approximately 1 percent without evaluation by an experienced designer.

The pump installation should include a gate valve, discharge check valve, pressure relief valve, and totalizing propeller-type flow meter on the discharge side of the pump. The suction line intake and strainer should be floated about 18 inches below the water level in the lagoon to withdraw the most solids-free liquid. Locate the pump as far from the lagoon inlet pipe as possible and upwind since solids tend to migrate, by wind and wave action, to the lagoon downwind side.

The availability of three-phase electric power lines will affect the wastewater irrigation system design. Without three-phase power lines, motor size is usually limited to 7.5 to 10 horsepower (hp) single-phase. A phase converter can be used to provide three-phase service from single-phase lines for larger pumps. This is usually at the farmer's expense. The most economical system uses smaller single-phase motors which limit horsepower. Using internal combustion engines is also an option, though not the most desirable.

Determining Needed Horsepower

Figuring the required motor or engine horsepower requires knowing the total system flow capacity (gpm), total dynamic head (TDH), and pumping plant efficiency.

Pump capacity. Multiply the number of sprinklers operating at the same time by the single sprinkler capacity to determine total system flow.

Total dynamic head. TDH includes sprinkler operating pressure, lateral and main line pipe friction, and elevation.

Use the accompanying worksheet to calculate TDH. Lateral line friction loss can be figured from an irrigation slide rule. Main line friction can be determined with an irrigation slide rule or friction loss table. These methods give friction loss per 100 feet of pipe. This friction loss factor is multiplied by the total pipe length divided by 100. The vertical distance between lagoon surface and the highest point in the field is the elevation difference.

Worksheet For Calculating Total Dynamic Head (TDH):

	psi	feet
sprinkler pressure =	_____	× 2.31 = _____
half of lateral		
friction loss =	_____	× 2.31 = _____
friction loss in		
main line =	_____	× 2.31 = _____
riser height	=	_____
elevation		
difference =		_____
Total (TDH) =		_____

Illustration:

sprinkler pressure =	55.0	× 2.31 =	<u>127.0</u>
half of lateral			
line friction loss =	(5.8 psi/2) = 2.9	× 2.31 =	<u>6.7</u>
friction loss			
in main line =	(1.01 psi/100 × 1010 ft)=10.2	× 2.31 =	<u>23.6</u>
riser height	=		<u>1.5</u>
elevation			
difference =			<u>25.0</u>
Total (TDH) =			<u>183.8</u>

To illustrate figuring pump capacity and TDH, assume that 7 Senninger 7025 RD-1-1 EFF sprinklers with 9/32-inch nozzles are being operated at the same time on a 2 1/2-inch lateral; 55 psi is the sprinkler pressure; the 3-inch main line is 1,010 feet long; pump capacity is 7 sprinklers × 17.1 gpm or 119.7 gpm; the highest point in the pasture is 25 feet above the lagoon minimum treatment level. The sum of these, TDH, is 183.8 feet. Pump capacity is 7 sprinklers × 17.1 gpm or 119.7 gpm.

Pumping plant efficiency is the overall efficiency of the pump and prime mover (motor or engine) and is always less than pump efficiency alone. Wastewater pump efficiency (regular irrigation) varies from around 50 percent for a small self-priming pump up to 80 percent or more for a large straight centrifugal pump. An efficiency range of 70 to 75 percent is typical of most wastewater pumps. Motor or engine efficiency varies. Either must provide the continuous horsepower needed to drive the pump. A typical overall pumping plant efficiency of 65 percent is used in the illustration.

Required horsepower. The equation for figuring motor or engine horsepower is:

$$HP = \frac{\text{pump capacity (gpm)} \times \text{TDH (feet)}}{3,960 \times \text{pumping plant efficiency}}$$

The motor horsepower, then, is:

$$HP = \frac{119.7 \text{ gpm} \times 183.8 \text{ feet}}{3,960 \times 0.65} = 8.54 \text{ hp}$$

The closest available motor size to 8.5 is 10 hp. This gives a little room for wear on the pump or sprinkler nozzles and friction loss in fittings. Sometimes 5 to 7.5 percent is added to the TDH to cover fittings friction loss. Adding 7.5 percent for fittings loss here would raise the required horsepower to 9.19 hp. The typical electric motor service factor of 1.05 to 1.15 would allow a 10-hp motor to provide 10.5 to 11.5 horsepower without damage, depending on the service factor on the particular motor chosen.

As a typical irrigation practice, extra horsepower is sometimes added to provide adequate system capacity and to allow for pump, motor, and sprinkler nozzle wear. In wastewater irrigation, however, extra horsepower is not usually added in a effort to hold down initial equipment cost.

Table 4 gives continuous horsepower needed as a general rule throughout Alabama to pump the amounts of water shown at pump discharge pressures of 80 to 85 psi. At higher pressures, water volume (gpm pumped) will be reduced. Pumping plants with overall pumping efficiency less than 65 percent will require higher continuous horsepower.

Table 4. Continuous HP Based On 65-Percent Pumping Plant Efficiency And 80 psi Pump Pressure.

GPM Pumped	Continuous (Electric Motor) hp
60 - 65	5.0
85 - 95	7.5
110 - 125	10.0
175 - 190	15.0
235 - 250	20.0
290 - 310	25.0

Target Land Area Needed

To minimize the amount of land and irrigation equipment needed, lagoon liquid is irrigated to supply optimum agronomic nitrogen rates to target crops. Table 5 lists the typical dairy, swine, and poultry layer lagoon liquid nutrient concentrations, irrigation rates, and minimum areas of fescue and bermudagrass pastures needed for controlled grazing. (These values should also be used when planning a new wastewater irrigation system.)

The application rates listed in Table 5 are selected to supply the necessary nutrients for crop growth and should not be exceeded to the point of causing soil or water quality problems. Choosing the target forage for controlled grazing is important. Both cool season and warm season grasses should be available for wastewater applications and forage production.

Wastewater should not be applied to forage grasses during dormancy. To prevent this, consider creating extra lagoon storage, using pastures with different forages, or overseeding the summer forage with a cool season grass such as ryegrass.

Wastewater Nutrient Analysis To Determine Application Rate

Both new and existing livestock operations should begin a program of periodic wastewater sampling for nutrient analyses to determine application rates. Nutrient concentrations vary from season to season. The Auburn University Soils Testing Lab analyzes wastewater for primary and secondary nutrients at a cost of \$24 per sample. Collect liquid lagoon samples from several locations, 6 inches below the surface, and 10 to 15 feet away from the bank or from the recycle system flush tanks. After combining representative samples from several locations, place about 1 liter into a clean 2-liter non-metallic container, iced or cooled. Transfer to the lab as soon as possible.

On-farm sampling for nitrogen, using either the Nitrogen-Meter or an electrical conductivity meter, is also possible.

One Example Of Wastewater Irrigation

A producer with a swine feeder-to-finish facility with 880 head wants to irrigate lagoon liquid onto bermudagrass pastures. The following calculations are based on the information in Table 5.

- The total lagoon liquid to be irrigated would be 30 acre-inches (880 head \times 0.034 acre-inch per animal group per year = 29.92).
- Total nitrogen concentration of the lagoon liquid, from the table, would be 136 pounds per acre-inch.

- The total annual plant available nitrogen would amount to 2,024 pounds N (880 head \times 2.3 pounds per animal group per year).
- The typical application rate for bermudagrass pasture would be 4.8 inches per year.
- Minimum pasture area needed would be 6.3 acres (880 head \times 0.0072 acres/per animal group).
- Four 880-head houses would require 25.2 acres of bermudagrass pasture for wastewater irrigation application (4 \times 6.3 acres).

Possible Problems With A Permanent Wastewater Irrigation System

Among factors that reduce efficiency and cause system failure are:

- The uneven distribution of wastewater resulting when large elevation changes within pastures or between the pasture and lagoon are not properly considered.
- Trying to pump high solids content wastewaters or slurry.
- Pumping from poorly maintained or undersized lagoons.

Conclusion

For properly sized swine, dairy, and poultry lagoons, the permanent irrigation system for application of wastewater for controlled grazing is a feasible and workable system. For best results consult a competent irrigation designer to design or verify individual systems.

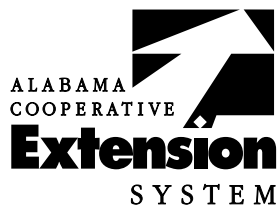

ANR-996

Ted W. Tyson, *Extension Agricultural Engineer*, Associate Professor, Agricultural Engineering, Auburn University

Adapted from: Sneed, Ronald E., and James C. Barker. 1989. Design and Specifications for Permanent Wastewater Irrigation Systems for Controlled Grazing. Biological and Agricultural Engineering, North Carolina State University, Raleigh, NC. Circular EBAE 135-89. North Carolina Cooperative Extension Service.

Printed by the Alabama Cooperative Extension System in cooperation with the Alabama Department of Environmental Management and the Environmental Protection Agency with Clean Water Act Section 319 Demonstration Funds.

Trade names are used only to give specific information. The Alabama Cooperative Extension System does not endorse or guarantee any product and does not recommend one product instead of another that might be similar.

For more information, call your county Extension office. Look in your telephone directory under your county's name to find the number.

Issued in furtherance of Cooperative Extension work in agriculture and home economics, Acts of May 8 and June 30, 1914, and other related acts, in cooperation with the U.S. Department of Agriculture. The Alabama Cooperative Extension System (Alabama A&M University and Auburn University) offers educational programs, materials, and equal opportunity employment to all people without regard to race, color, national origin, religion, sex, age, veteran status, or disability. UPS, 2M21, New 3:97, ANR-996