

Eastern Bluebirds

The early American settlers called it the "blue robin" because of its rust-colored breast and blue back and tail. Today, we call it the Eastern bluebird. Observing this beautiful bird can bring hours of enjoyment. It is easily attracted to homes and surrounding open areas when nesting boxes are correctly constructed and properly placed. Youth organizations and school classes can construct and maintain bluebird boxes for educational and money-making projects.

The Eastern Bluebird

Life History

The bluebird, like the robin, prefers open areas such as roadsides, cutover woodlands, old orchards, parks, and yards in cities and towns. In these areas, the bluebird tries to find a hollow tree (cavity tree) in which to build a loosely woven nest of grasses.

These cavities are often hard to find, because non-native species such as the house sparrow and starling also use cavities for nesting. These exotic species are very aggressive and often take cavities bluebirds could use. Fortunately, the bluebird will also use man-made cavities, like boxes, for nesting. The boxes can be built to prevent larger birds, such as starlings, from using them.

Normally bluebirds produce 2 to 3 broods per year in Alabama. The female begins the first nest in mid-April. She lays one light-blue egg per day for 4 to 6 days. The female incubates the eggs for about 12 days. Soon after hatching, the young bluebirds begin sprouting feathers. At this time, bluebirds have a gray back and spotted white breast, with only a hint of blue on their wings and tail. Young birds remain in the nest for about 15 days after hatching.

The male is in charge of the young bluebirds when they leave the nest. He feeds them and teaches them how to find food to feed themselves. He continues this training phase for several days after they leave the nest. While the male is busy with the fledglings, the female remodels the old nest or builds a new one for a second brood.

In the yard and around the garden, bluebirds consume grasshoppers, flying insects, beetles, and caterpillars. They also eat berries and fruits found near their nests, especially during the winter when insects are scarce.

Population Decline

During the last 60 years, bluebird numbers have decreased 90 percent in the eastern United States. There are four reasons for the decline:

- The widespread use of insecticides decreases food supplies.
- Severe winters increase winter mortality
- Changing agricultural practices create well-trimmed orchards with no cavity trees for nest sites.
- Exotic species competing for remaining nest sites make nesting even more difficult.



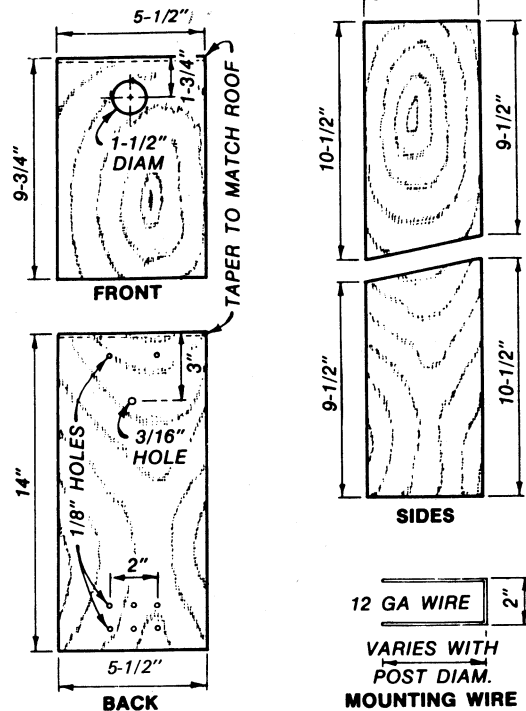
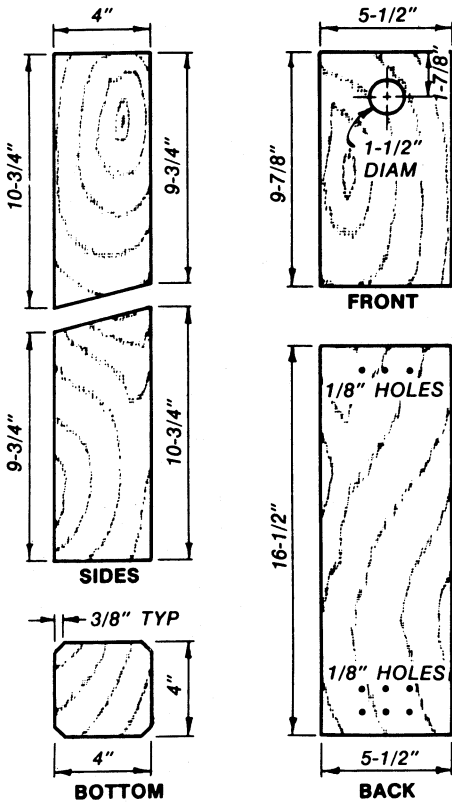
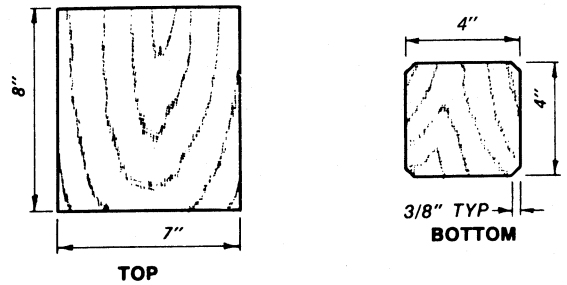
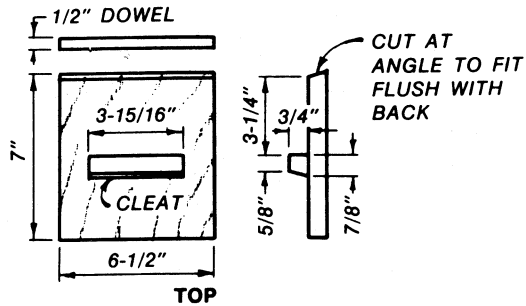
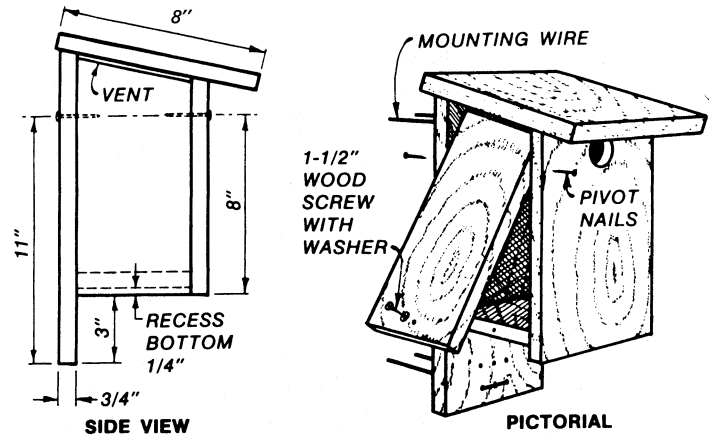
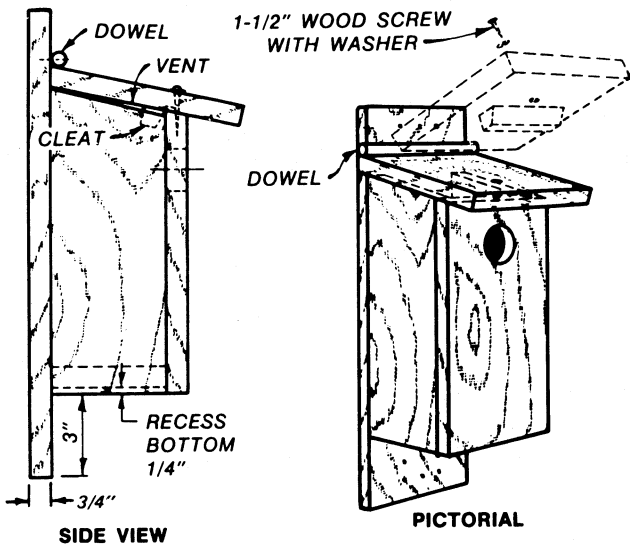

Construction details for a top-opening bluebird nest box.

Construction details for a side-opening bluebird nest box.

Helping Bluebirds

Finding suitable nest sites is perhaps the most severe problem the bluebird faces today. Allowing trees to mature and develop natural cavities takes too long. A much quicker solution is to provide manmade wooden nest boxes. These boxes take little time to build, erect, and maintain. When boxes are placed in good areas, bluebird populations increase rapidly.

Providing nest boxes can be a very rewarding hobby for individuals, clubs, and classes. Not only are bluebirds pleasing to observe, but the activities of box maintenance and checking are "hands-on" educational experiences in bird biology. Clubs and other organizations can also earn money by building and selling bluebird nest boxes.

Building Nest Boxes

When constructing bluebird nest boxes, keep two points in mind.

- Make the boxes the correct size.
- Make the boxes easy to clean.

Both of the boxes illustrated here are sized for bluebirds and designed for easy maintenance.

Several important design and construction features must be included to make your box attractive and safe for bluebirds. These features are listed below.

Use 1-inch-thick (usually finished to 3/4 inch) rough-sawn lumber. Pine, cedar, cypress, or even exterior plywood are all good for box construction. If you use pine or plywood, it must be painted to resist decay. If painting is necessary, paint the boxes on the outside only. Use light colors (light gray, white, tan) if the boxes will be mounted in a sunny location. Use darker colors (browns or greens) if they will be mounted in the shade.

Do not use treated wood for box construction.

Be sure to provide drain and ventilation holes as shown in the diagrams. This is important to keep the young bluebirds dry and to prevent overheating.

Do not provide a perch. Bluebirds need no perch, and perches attract house sparrows to the box.

Mounting Nest Boxes

Mount nest boxes on fence posts, private utility poles, tree trunks, or metal posts. Attach the boxes only through the hole at the top of the back piece so that they can be inverted for easy cleaning. Nail or screw the boxes to wood or metal posts. A piece of wire going around the bottom of the box and the mounting structure will keep the box from swinging too much.

When mounting nest boxes, make it difficult for predators to get into them. Less predation occurs with metal posts because predators such as house cats, rac-

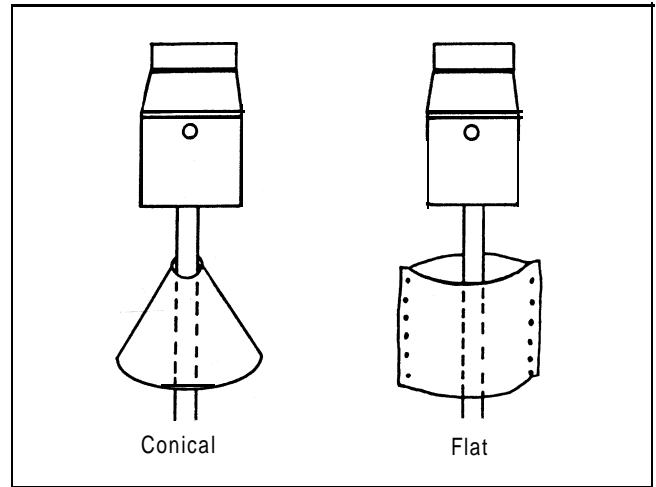

Plan for sheet-metal predator guard.

coons, and snakes have trouble climbing on smooth metal. Coating the metal posts with grease or "Tree Tanglefoot" during the nesting season can reduce predation even further. A cone-shaped or flat sheet-metal baffle placed just below the box on wooden posts can also reduce predation. If predation does occur and eggs or young are destroyed, the parents will usually re-nest in another box nearby.

Location Of Boxes

Put nest boxes up by the end of February in areas around open fields, pastures, golf courses, cemeteries, gardens, and large lawns which provide excellent bluebird habitat. These areas usually provide plenty of insects to eat. Avoid areas where insecticides are used heavily for two reasons:

- Insects, a favorite bluebird food, are reduced, and the birds have trouble finding enough to eat.
- The insects left are usually covered with insecticide. Bluebirds may be poisoned when they eat these insects.

Place boxes 4 to 6 feet above the ground and 50 to 100 yards apart. Face the boxes to the south or southeast, if possible. Try to select places where trees, shrubs, utility wires, or fences are within 25 to 100 feet of the boxes. Bluebirds use these structures for perches when feeding. These perches are also helpful to young birds during their first flights.

If boxes are located near woods and brush piles, other species of birds, such as chickadees, titmice, nuthatches, and wrens, will use the bluebird boxes. These species, like the bluebird, are welcome additions to the area and should not be discouraged from using the boxes. These birds are also helpful in controlling insect populations. It may be possible to get a bluebird to nest in the same area by placing another box about 10 to 20 feet from the one the other bird is using.

Checking Boxes

Checking bluebird boxes regularly provides information on bluebird productivity. It is not necessary to check boxes. Bluebirds will nest and produce young even if the boxes are not checked regularly. However, it is fun to see the boxes you constructed and mounted being used!

Starting in early March, check the boxes once a week and continue to do so until July. To check a box, carefully open it and look in. Look for evidence of nest building, eggs, or any other signs of bird activity. Be sure to record when nest building begins, when and how many eggs are present, and when and how many birds hatch.

Tap the box before opening it so the female can leave; she will return after a little while. **Do not** check the boxes during the following two periods:

- During the first 3 days of egg laying, do not disturb the female in the morning hours. This is when she actually lays the eggs. Just remember that when you see nest construction almost completed, start checking the box in the late afternoon.

- During the last 3 days before the young birds leave the box (when they are about 10 days old), do not disturb them at any time of the day. A disturbance at this time can cause the young to leave the box prematurely. If the young leave the box too early, they may starve or be killed by a predator.

During the summer after the young birds leave, clean out the old nest material so re-nesting can occur. After the last brood leaves late in the summer, leave nesting material in the box over the winter. This old material provides better insulation for birds taking refuge in the boxes on cold winter nights. In February of the following year, clean and repair the boxes for the new nesting season.

Bluebird Food

Although the bluebird's diet is made up mostly of insects, they do eat berries and fruits. You can improve your yards and gardens as bluebird habitat by planting some of the shrubs and trees listed below. Both bluebirds and other songbirds will benefit from these plantings.

Autumn olive	Viburnum
Bayberry or wax myrtle	Wild grape
Blackberry	Cedar
Blueberry	Cherry
Elderberry	Dogwood, Flowering
Greenbriar	Holly
Hackberry	Lespedeza
Honeysuckle	Oaks
Mulberry	Pine
Serviceberry (shadbush)	Sumac

For More Information

More information on bluebirds and nest boxes is available from these sources:

Non-Game Wildlife Program Coordinator
Department of Conservation and Natural Resources
64 North Union Street
Montgomery, AL 36130-4901
Telephone: 205-242-3469.

North American Bluebird Society
Box 6295
Silver Spring, MD 20906.



ANR-687

This publication was adapted from "Eastern bluebirds: how to build and place nesting boxes" by Lee Stribling and Gary San Julian, North Carolina Agricultural Extension Service, Pamphlet No. AG-287.

Illustrations were adapted from the work of John R. Harris, Scientific Illustrations Section, IPD, under the supervision of Aubrey W. Stephens, Jr.

Recommended for Extension use by H. Lee Stribling, *Extension Wildlife Scientist*, Associate Professor, Zoology and Wildlife Science, Auburn University.

For more information, call your county Extension office. Look in your telephone directory under your county's name to find the number.

Issued in furtherance of Cooperative Extension work in agriculture and home economics, Acts of May 8 and June 30, 1914, and other related acts, in cooperation with the U.S. Department of Agriculture. The Alabama Cooperative Extension System (Alabama A&M University and Auburn University) offers educational programs, materials, and equal opportunity employment to all people without regard to race, color, national origin, religion, sex, age, veteran status, or disability. UPS, 15MO6, Rep. 10:96 ANR-687